

Math 9 Final Exam Review 2

Simplify the following

1. $10 \times (-2) \times 4 \div 5 + 7$

2. $(-1 + 17) \times (-2) + 15 \div (-3)$

3. $9 + (-2) \times 8 \div 4 - 11 \times (-3)$

4. $\frac{3}{5} \div \frac{-7}{10} + \left(\frac{-1}{-2}\right)$

5. $\frac{-5}{8} \div \left(\frac{1}{4} + \frac{-2}{3}\right) - \frac{3}{4}$

6. $\left(\frac{7}{8} - \frac{1}{4}\right) \times \frac{-1}{2} \div \frac{5}{8}$

7. $\left(\frac{-2}{5}\right)\left(\frac{1}{3}\right) + \left(\frac{1}{-4}\right) \div 2$

8. $-\frac{1}{6} + \left(\frac{5}{3}\right)\left(\frac{-1}{2}\right)$

9. $\left(\frac{-2}{5}\right)^2 \div \frac{2}{3} - \left(\frac{-7}{10}\right)$

10. $-\frac{3}{10} + \left[\frac{-1}{3} \times \left(\frac{-3}{5}\right)\right]$

11. $2\frac{1}{7} \times \frac{-1}{3} + \left(-1\frac{2}{7}\right)$

12. $3\frac{3}{4} - \left(-2\frac{5}{8} + 1\right)\left(\frac{5}{9} - 2\right)$

13. Order the following from least to greatest. Show on a number line

$-2.5, -\frac{5}{3}, 0.95, -1\frac{1}{2}, -0.8$

14. Determine the volume of a cube with side length of 8 cm.

15. Simplify $(2^5 \times 4^3)^2$

16. Simplify $\left(\frac{5^3}{5}\right)^4$

17. Evaluate $\sqrt{\frac{81}{49}}$

18. Calculate the side length of a square with an area of 5.2 cm^2

19. Express $\sqrt{\frac{32}{19}}$ to 2 decimal places :

20. Complete the table.

Power	Base	Exponent	Repeated Multiplication	Value
2^7				

21. Evaluate the following. Answer in fraction form if necessary. (No decimals)

a) $\sqrt{\frac{121}{36}}$ b) $-(-2)^3$ c) $(2 \times 3^4)^0$ d) $\left(-\frac{2}{5}\right)^2$
 e) $\left(-\frac{1}{4}\right)^3$ f) $(-0.2)^3$ g) -5^0 h) $(-1)^{98}$

22. Evaluate:

a) $5^2 - 2^5 \div 8 \times 2 + (-1)$ b) $(4^2 - 1)^0 \times 10 \div (-5)$
 c) $(-3)^2 + 2^2 - 3^3$ d) $5^2 - 2^3 \times 6 \div 3 + 2^0$

23. Express 32^3 as a power with a base of 2.

24. Express the following as a single power with the **lowest** base. Show all steps – answers produced by calculator only will not receive full marks.

a) 9^5 b) $\left(\frac{8^6}{4^7}\right)^3$ c) $27^4 \div 9^6$

25. . A cube has a volume of 512 cm^3 . Determine the length of one side and express your answer as a power with the lowest possible base.

26.. Express as a single power, where possible.

a) $(3^6)^5 \div (3^4)^3$ b) $\frac{(2^3 \times 7^5)^4}{(2^4 \times 7^2)^3}$ c) $\frac{(10^5)(10^2)^4}{10^8}$
 d) $\left(\frac{5^4}{3^2}\right)^3$ e) $(2^3 \times 3^5)^4$ f) $(3^2 \times 27^2)^2$

27. . Determine the value of the missing number.

a) $16^3 = (2^6)^{\square}$

b) $36^2 = 6^{\square}$

c) $16^2 = \square^4$

28. . A cube has a side length of 25 cm.

a) Show the volume of the cube as a power, with the lowest base.

b) Show the surface area as a power, lowest base.

c) Another cube has a **volume** of 5^4 cm^3 . How many times greater is the volume of the larger cube?

29. Simplify into expressions containing positive exponents

a) 3^{-5}

b) $(-4)^{-2}$

c) -2^{-6}

d) $\left(\frac{2}{3}\right)^{-3}$

30. The area of a square is 41.94 cm^2 . Find the side length of the square.

31. Determine the length of the missing side of the right triangle

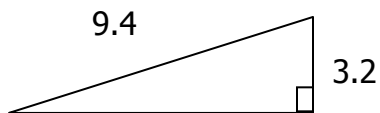

32. Ryan drew a scale drawing of a rectangular field that is 80m by 120m. He used a scale in which 1 cm represents 2.5 m. Determine the dimensions of the scale drawing.

33. Show that $\triangle CAT$ is similar to $\triangle ODG$.

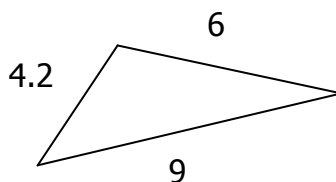
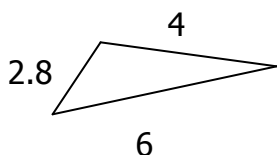

34. Measure the dimensions of the rectangles and determine if they are similar. Show work and explain your answer.

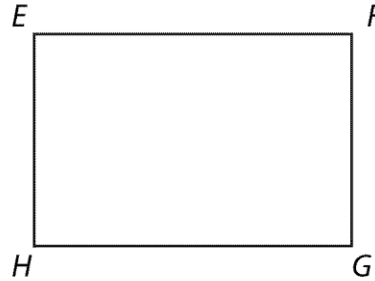

35. $\triangle ABC \sim \triangle DEF$. Determine the lengths of EF and DF .

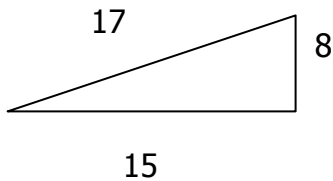

36. A person 1.8 m tall has a shadow 2.52 m long. At the same time, a lamppost has a 3.5m shadow. Calculate the height of the lamppost.

37. Draw a similar shape using the following scale factors. Show your work, the measures of the angles, and the lengths of each side.

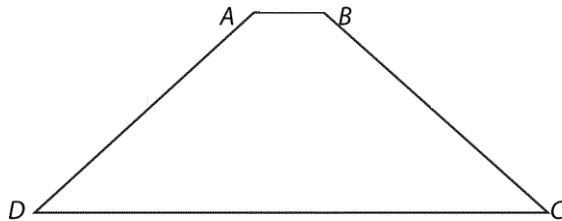

- a) A reduction by a scale factor of 80%.
- b) An enlargement by a scale factor of 1.5

38. Find the surface area of the following composite shapes

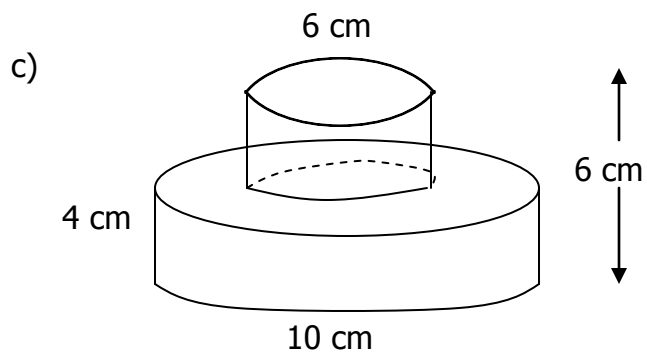
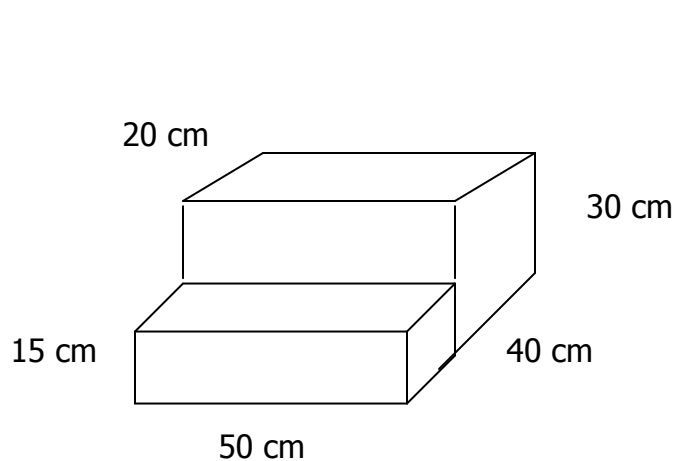
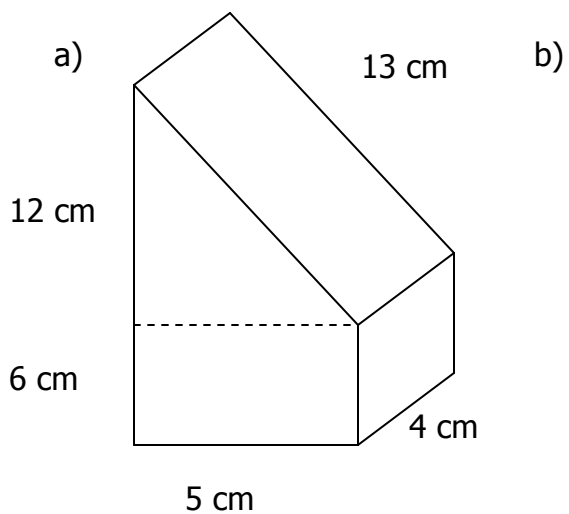

39. Find the area of the composite shape

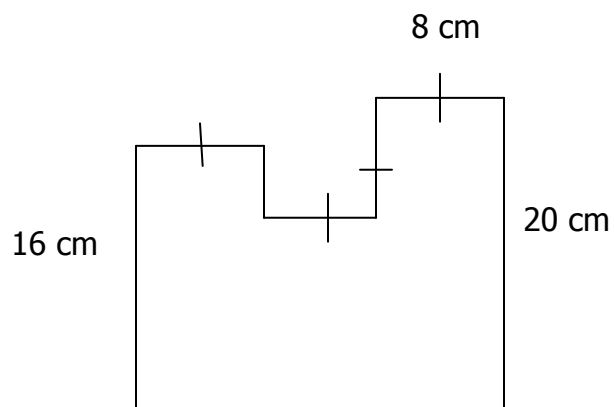

40. Find the diameter of the circle below

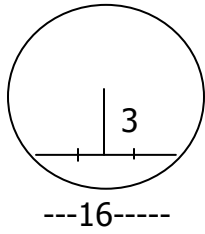

41. Find the values of the missing angles, below

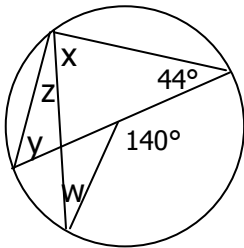

42. Find the values of the missing angles, below

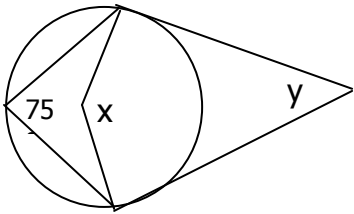

43. Find the value of x for the diagram below

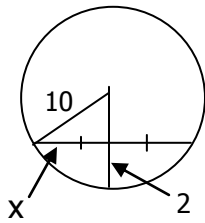

44. Find the unknown angles for the diagram below

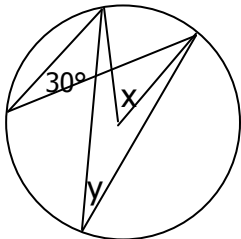

45. Find the measures of the missing angles in the diagram below

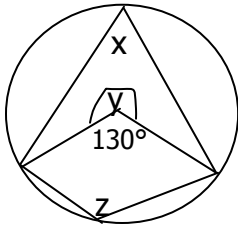

46. Find the measures of the angles in the diagram below

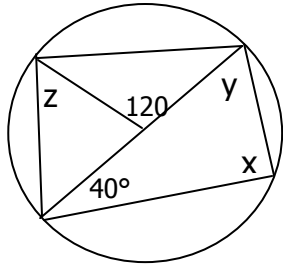

47. Find the perimeter of $\triangle ABC$

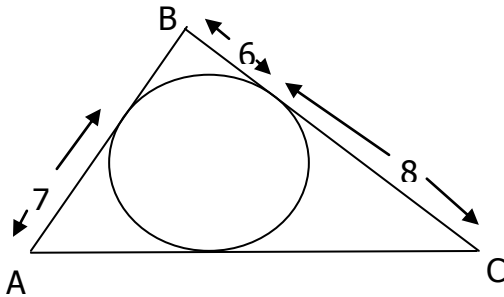

48. Dave mows the grass at a golf course. He charges \$6/h plus a flat fee of \$10. If h represents the number of hours he works, and C represents his total fee, determine the equation that represents what he charges.

49. Determine the relation that matches the table of values.

x	1	2	3
y	7	9	11

50. Determine the relation that matches the table of values.

x	1	2	3
y	7	4	1

51. Determine the rate of change for the relation $y = 5x - 4$.

52. Ben has \$120 in his account. Each month he deposits \$15. Let t represent the time in months and A represent the account balance. Create a table from $t = 0$ to 6 then graph. What is the rate of change?

53. Graph and label $x - 2y = 4$ using a table of values

54. Graph and label $x = 3$

55. Determine which situation matches the graph.

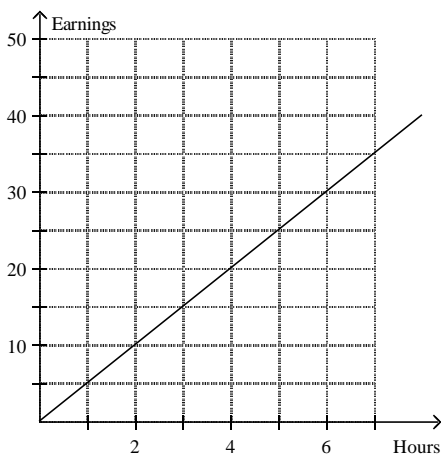

- A. David earns \$5/h tutoring. C. Sandra earns \$4/h babysitting.
B. Eric earns \$6.50/h painting. D. Henry earns \$4.50/h mowing lawns.

56. Solve the following equations

a) $\frac{x}{3} - \frac{x}{2} = -2$. b) $3(x+2) = x-4$ c) $\frac{3x}{2} + 1 = 5$ d) $4x+5-x = 2x-4x+8$

57. The perimeter of a rectangle is 48 cm. The length is 15 cm less than the twice the width. Determine the dimensions of the rectangle.

58. Determine the inequality that matches the number line.

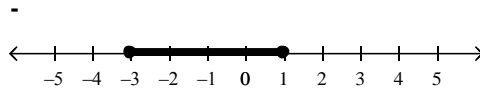

59. Determine which inequality matches the number line.

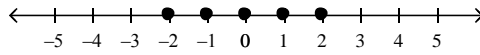

60. For the linear relation $y = 2x + 3$, create a table of values then graph on the grid provided.

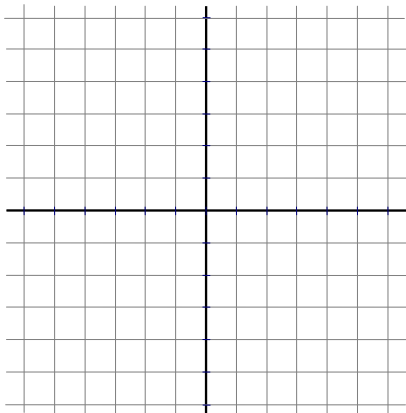

x	y
-1	
0	
1	
2	

61. A linear relation passes through $(-1, 3)$ and $(2, 9)$. What is the rate of change?

62. Graph the following inequalities.

a. $x \leq -4$, where x is an Integer

b. $-1 < x \leq 3$, where x is a Real Number

63. Solve and graph the following inequalities.

a. $6x - 1 \geq 11$, where x is an Integer b. $-2a > 4a - 12$, where x is a Real Number

64. Jesse is three times Ryan's age. In five years, the sum of their ages will be 42. Write and solve an equation to determine Ryan's current age.

65. Determine the degree of the polynomial $3xy^4 - 2x^2y + 5x$.

66. Determine the coefficient of x in the polynomial $4 - x$.

67. Determine the constant term in the polynomial $5 - x + 2x^3$.

68. Evaluate the polynomial $3x^2 + 2x - 8$ if $x = 5$.

69. Determine the sum $(5x^2 - 2x + 7) + (3x^2 - 2x - 5)$.

70. Subtract $(5x^2 - 11x - 6) - (-x^2 + 7x - 3)$.

71. Determine the product of $-2x$ and $(7x - 3)$.

72. Determine the product of $(3a - 1)(a + 4)$

73. Determine the quotient of $(16x^3y - 12x^2y^2 + 24xy) \div (-4xy)$.

74. Determine the missing factor in $(?)(-2x + 5) = 10x - 25$.

75. Complete the table for each polynomial.

	<i>Degree</i>	<i># of terms</i>	<i>Coefficients</i>	<i>Variables</i>
a) $2x^4y^2 - 7xy^3$				
b) $-2a^5b^2 - ab^3 + 4b^6$				
c) $3x^2yz + 4yz - 8z^2$				

76. Express the perimeter of this rectangle as a polynomial and simplify.

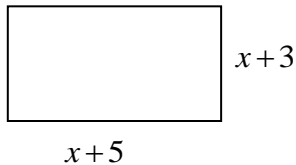

77. A rectangle has a perimeter of $(16x+24)$ cm. If the width is $(3x+4)$ cm. find the length.

78. The perimeter of the triangle below is $15x-6y$. Show an expression that determines the length of the missing side and then simplify completely.

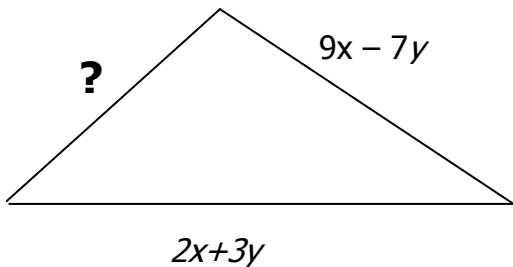

79. The diameter of a large circular pipe is 24 m. There is water running through the pipe; the water covers only the bottom part of the pipe. The width of the water's surface across the pipe is 16 m. How deep is the water?

Math 9**Final Exam Review 2---Key**

- 1) -9 2) -37 3) 38 4) $-\frac{5}{14}$ 5) $\frac{3}{4}$
- 6) $-\frac{1}{2}$ 7) $-\frac{31}{120}$ 8) -1 9) $\frac{47}{50}$ 10) $-\frac{1}{10}$
- 11) -2 12) $\frac{101}{72}$ 13) -2.5, $-\frac{5}{3}$, $-1\frac{1}{2}$, -0.8, 0.95
- 14) 512 cm^3 15) 2^{22} 16) 5^8 17) $\frac{9}{7}$ 18) $\approx 2.28 \text{ cm}$.
- 19) 1.30 20) 2; 7; $2 \times 2 \times 2 \times 2 \times 2 \times 2 \times 2$; 128
- 21) a) $\frac{11}{6}$ b) 8 c) 1 d) $\frac{4}{25}$ e) $-\frac{1}{64}$ f) -0.008 g) -1 h) 1
- 22) a) 16 b) -2 c) -14 d) 10 23) 2^{15} 24) a) 3^{15} b) 2^{12} c) 1
- 25) 2^3 26) a) 3^{18} b) 7^{18} c) 10^5 d) $\frac{5^{12}}{3^6}$ e) $2^{12} \times 3^{20}$ f) 3^{16}
- 27) a) 2 b) 4 c) 4 28) a) 5^6 b) 6×5^4 c) 5^2
- 29) a) $\frac{1}{3^5}$ b) $\frac{1}{(-4)^2}$ c) $\frac{1}{-2^6}$ d) $\left(\frac{3}{2}\right)^3$ 30) ≈ 6.48 31) 8.84
- 32) 32 cm by 48 cm 33) $\frac{9}{6} = \frac{6}{4} = \frac{4.2}{2.8}$ 34) $6:4 = 1.5$ $4:2.8 = 1.43$ Not similar
 $1.5 = 1.5 = 1.5$
- 35) EF = 19.2, DF = 40.8 36) 2.5 m high 37)
- 38) a) 268 cm^2 b) 8800 cm^2 c) 320.44 cm^2
- 39) 608 cm^2 40) 17.09 41) $x = 70, y = 46, z = 20, w = 26$

42) $x = 150, y = 30$

43) $x = 6$

44) $x = 60, y = 30$

45) $x = 65, y = 230, z = 115$

46) $x = 90, y = 50, z = 60$

47) $P = 42$

48) $C = 6h + 10$

49) $y = 2x + 5$

50) $y = -3x + 10$

51) $r/c = 5$

52) $A = 15t + 120; r/c = 15$

53)

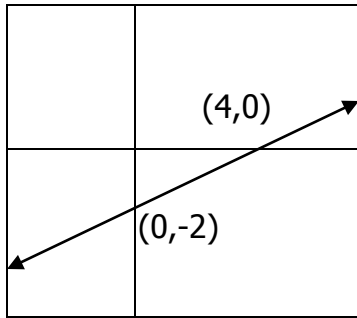

54)

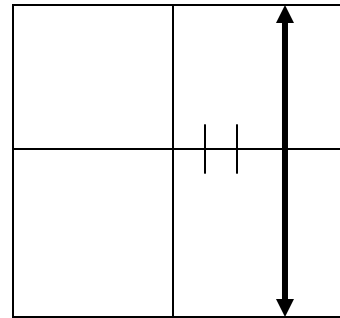

55) Choice A

56) a) $x = 12$

b) $x = -5$

c) $x = \frac{8}{3}$

d) $x = \frac{3}{5}$

57) 13 by 11

58) $-3 \leq x \leq 1, x \in \text{Rationals}$

59) $-2 \leq x \leq 2, x \in \text{Integers}$

60)

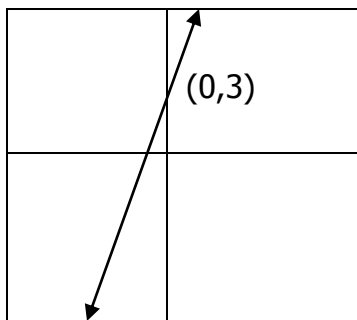

61) $r/c = 2$

62) a)

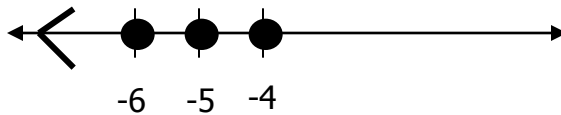

b)

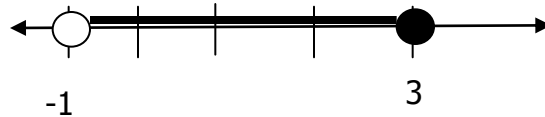

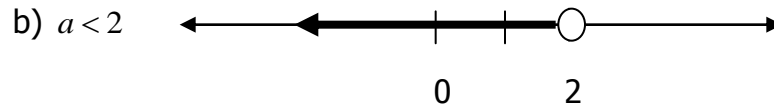
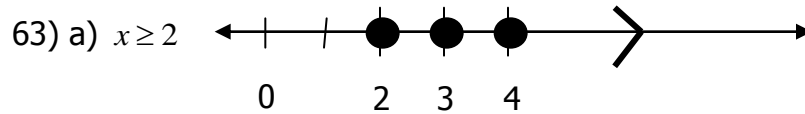

64) Ryan is 8 years old

65) degree is 5

66) co-efficient is 1

67) constant is 5

68) 77

69) $8x^2 - 4x + 2$

70) $6x^2 - 18x - 3$

71) $-14x^2 + 6x$

72) $3a^2 + 11a - 4$

73) $-4x^2 + 3xy - 6$

74) (-5)

75) a) 6; 2; 2 and 7; x and y;

b) 7; 3; -2 and 1 and 4; a and b

c) 4; 3; 3 and 4 and 8; x and y and z

76) $P = 4x + 16$

77) $5x + 8$

78) $4x - 2y$

79) The water is 3.06 m in depth